

Announcements

- we have organized reviews this Thursday and Friday - all in 166 Roessler
- practice exam on the web
- I will be here all week - my door is, as always, open to you
- final exam: 12/16 10:30 am -12:30 pm in Chem 179 (DL 1-3) and 194 (DL 4-11)

Oscillations

Physics 7B - Lecture 8

Prof. Conway

The Basic Idea

If you have a system described by a parameter (position for example) where there is a force counteracting the parameter, the system

oscillates

Oscillations are, of course, the basis of waves...

Examples: 1D Oscillations

- mass on a spring
- vibrating string
- diatomic molecule
- pendulum
- RLC circuit

All of these can be described as
“simple harmonic oscillators”

Mass and Spring

- consider a mass connected to a spring
- the mass slides frictionlessly on a horizontal surface
- the mass oscillates in 1 dimension:

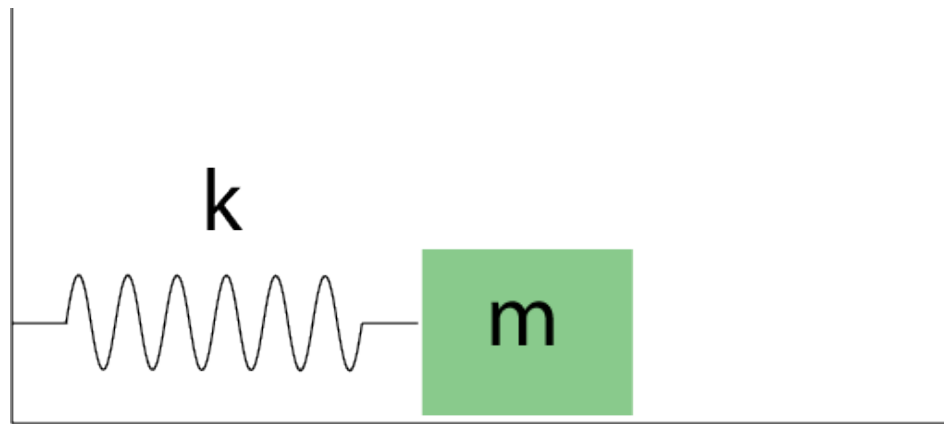

Mass and Spring

If mass is displaced from its initial (unstretched) position, there is a force tending to push it back to the middle, where there is zero force:

Hooke's Law: 1676
ceiinossstuv

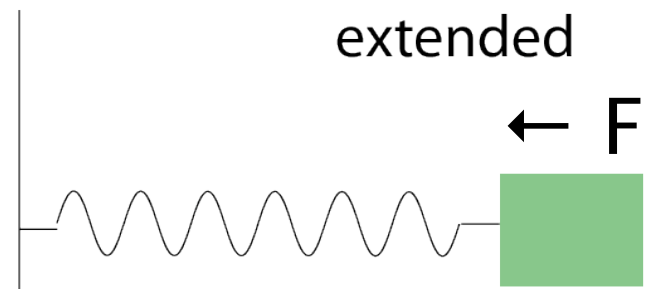
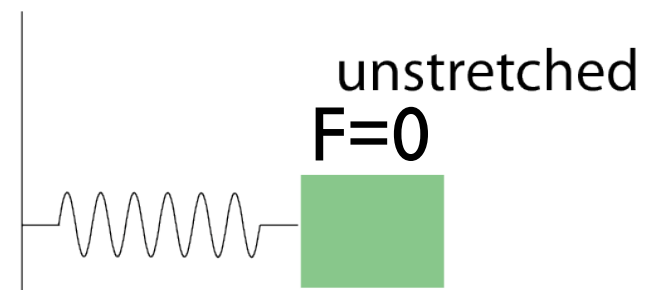
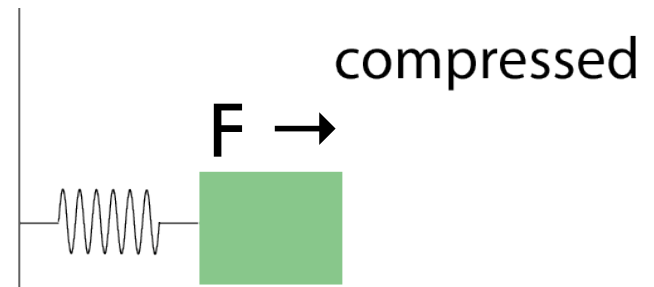

Hooke's Law

- “with the extension goes the force”
- the force is proportional to, and opposed to, the displacement of the mass

$$F = -kx$$

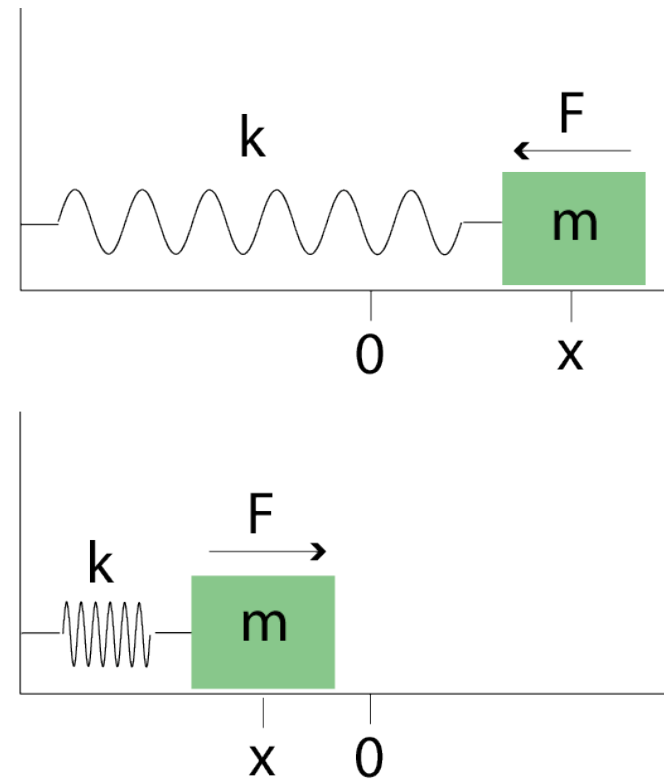

k : spring constant (N/m)

Double Spring - PPS

Suppose we have a mass connected to two springs with spring constant k . Then

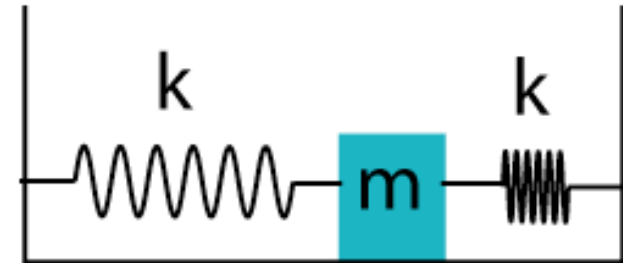

- A. $F = -kx$
- B. $F = -kx/2$
- C. $F = 0$
- D. $F = -2kx$
- E. $F = -kx^2$

Simple Harmonic Oscillator

$$F = -kx$$

$$F = ma = m \frac{d^2 x}{dt^2}$$

$$\frac{d^2 x}{dt^2} = -\frac{k}{m}x$$

We seek a function $x(t)$ whose second derivative is that function multiplied by a negative constant!

Simple Harmonic Oscillator

- we can write a general solution of the form

$$x(t) = A \cos(\omega t + \phi)$$

amplitude



angular
frequency

phase

Simple Harmonic Oscillator

- we can write a general solution of the form

$$x(t) = A \cos(\omega t + \phi)$$

- check if it solves the equation:

$$\omega = \sqrt{\frac{k}{m}}$$

Simple Harmonic Oscillator

- can also write it as

$$x(t) = A \cos\left(\frac{2\pi t}{T} + \phi\right)$$

$$\omega = \frac{2\pi}{T}$$

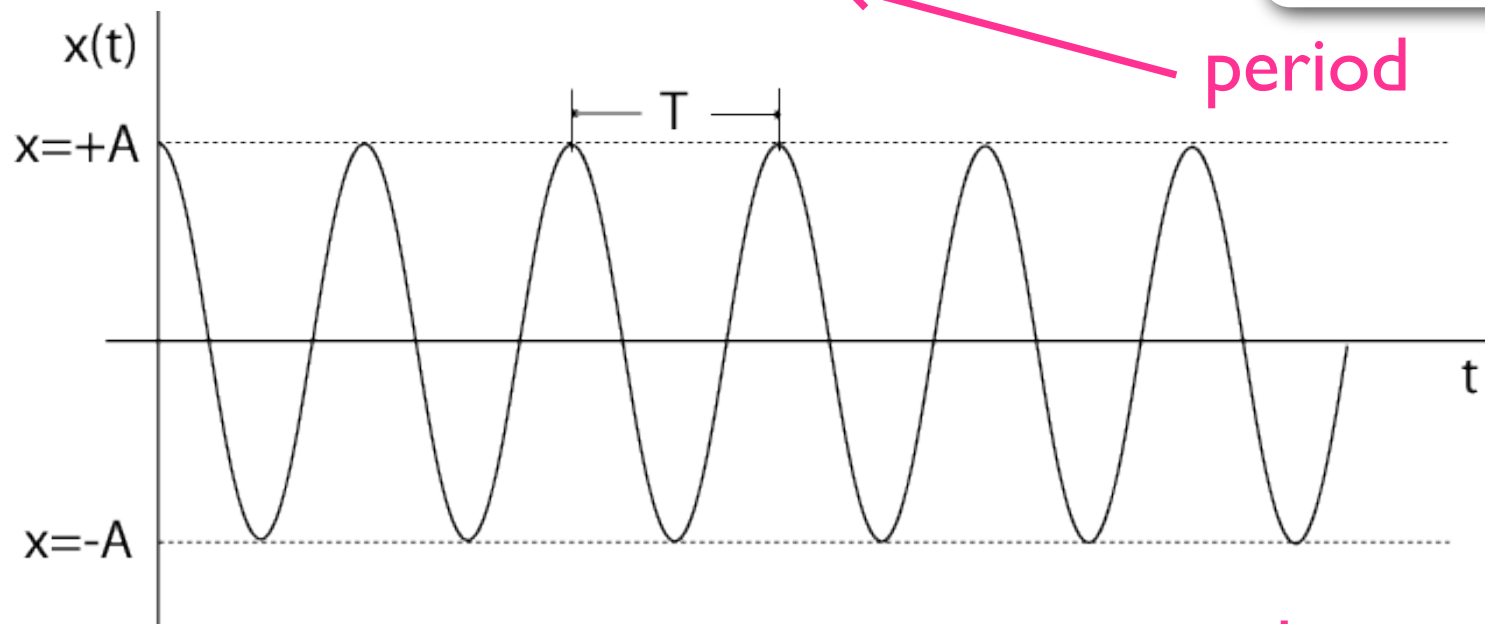

what about ϕ ?

Simple Harmonic Oscillator

- value of ϕ comes from initial conditions
- suppose that at $t=0$, $x=A$:

$$x(t = 0) = A \cos(0 + \phi) = A \cos \phi = A$$

$$\Rightarrow \phi = 0$$

$$x(t) = A \cos\left(\frac{2\pi t}{T}\right)$$

Frequency/Period

- frequency = number of oscillations per second = 1/period
- $f = 1/T$

$$x(t) = A \cos\left(\frac{2\pi t}{T}\right) = A \cos\left(\sqrt{\frac{k}{m}}t\right)$$

$$\frac{2\pi}{T} = \sqrt{\frac{k}{m}}$$

$$T = 2\pi \sqrt{\frac{m}{k}}$$

bigger mass: longer period
stiffer spring: shorter period

period does not
depend on amplitude!

Frequency/Period PPS

Your car's engine is rotating with a frequency of 30 Hz. The period of rotation is

- A. 30 sec
- B. $1/30$ sec
- C. 2 sec
- D. $1/2$ sec

Energy and Amplitude

- force is gradient (derivative) of potential
- spring potential energy is quadratic in the position

$$U(x) = \frac{1}{2}kx^2$$

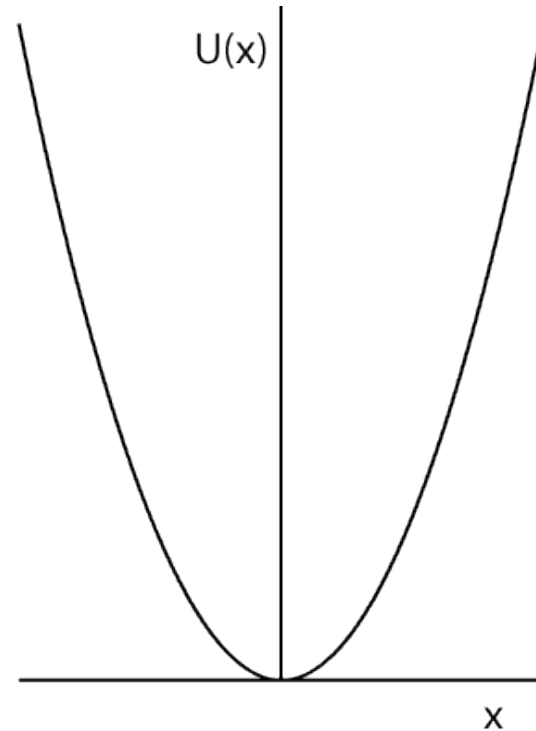

Energy and Amplitude

- kinetic energy depends on velocity:

$$x(t) = A \cos\left(\frac{2\pi t}{T}\right)$$

$$v(t) = \frac{d}{dt}x(t) = \frac{d}{dt}A \cos\left(\frac{2\pi t}{T}\right)$$

$$v(t) = -A\left(\frac{2\pi}{T}\right) \sin\left(\frac{2\pi t}{T}\right)$$

- velocity is zero when mass is at extreme ($x = +A$ or $x = -A$) !

Energy and Amplitude

- energy goes back and forth between kinetic and potential!
- total energy is constant!

$$E_{\text{tot}} = K + U$$

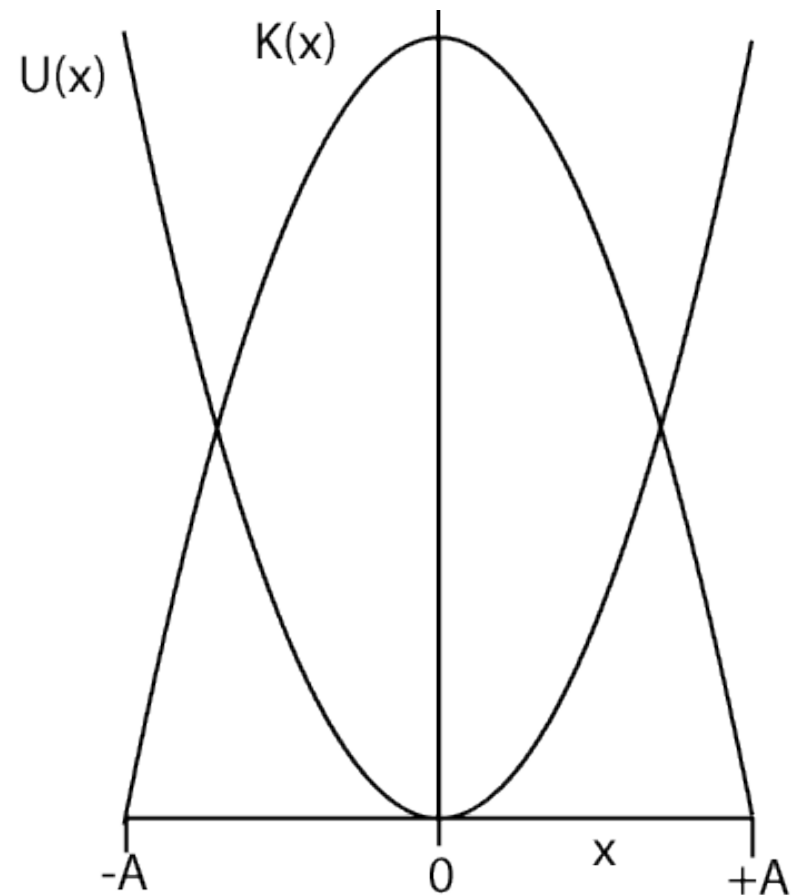

Energy and Amplitude

- we therefore know that the total energy is

$$E_{tot} = \frac{1}{2}kA^2$$

- we can also get the maximum velocity ($x=0$):

$$v_{max} = \sqrt{\frac{k}{m}}A$$

Energy/Amplitude - PPS

A certain mass-spring oscillator has a total energy of 5 J. If we double the spring constant, and make the amplitude half as great, the total energy becomes

- A. 2.5 J
- B. 5 J (no change)
- C. 10 J
- D. 20 J
- E. 25 J

Mass-Spring Animations

- A number of decent animations exist on line depicting simple harmonic oscillation:

<http://www.phy.ntnu.edu.tw/ntnujava/viewtopic.php?t=236>

<http://www.walter-fendt.de/ph11e/springpendulum.htm>

<http://www.colorado.edu/physics/phet/simulations/massspringlab/MassSpringLab2.swf>

Plane Pendulum

- consider mass swinging from a string

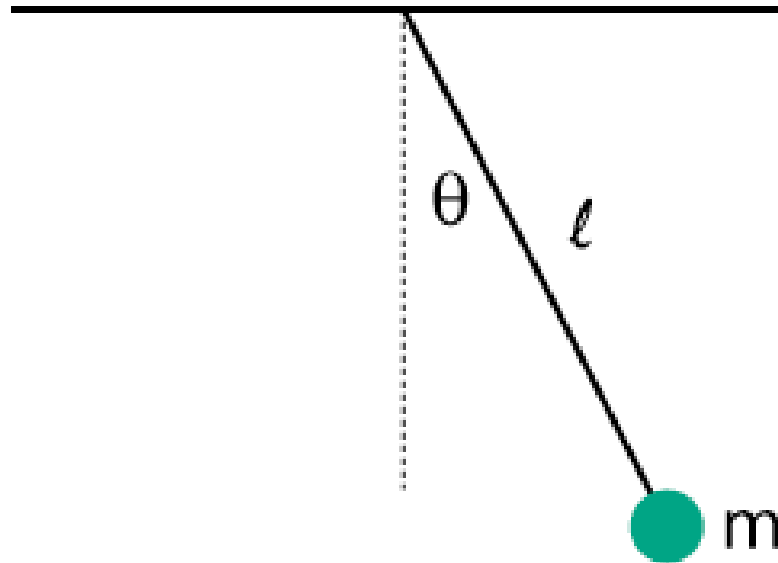

- gravity is always pushing it back to center!

Plane Pendulum

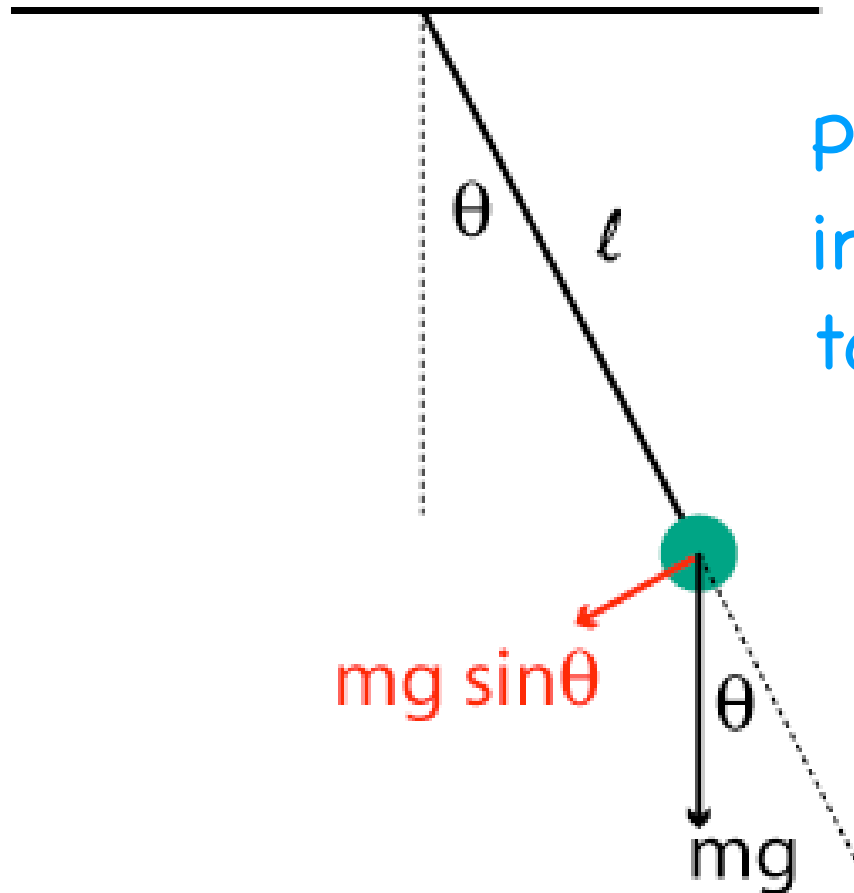

Pendulum can move only in direction perpendicular to string.

Force along motion is given by projecting mg along that direction

Plane Pendulum

- we can now write down the equation governing the angle as a function of time:

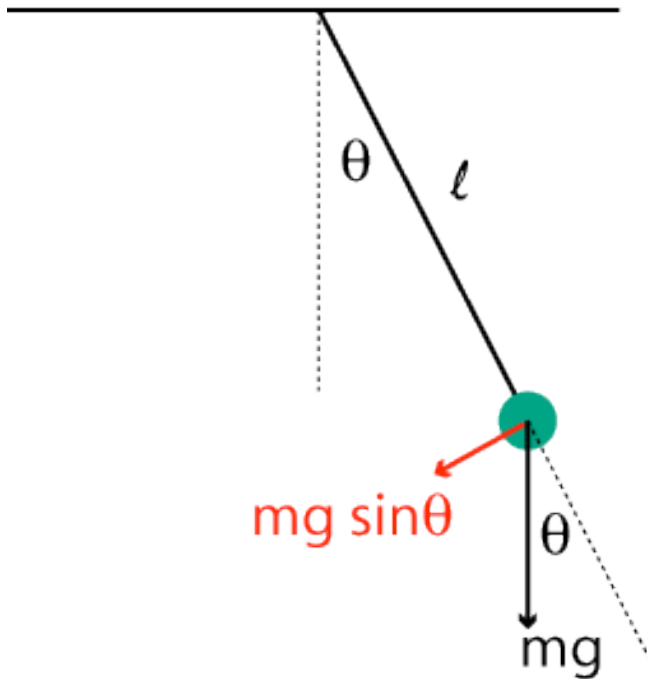

$$m\ell \frac{d^2\theta}{dt^2} = -mg \sin \theta$$

$$\text{small } \theta : \sin \theta \approx \theta$$

$$\Rightarrow \frac{d^2\theta}{dt^2} = -\frac{g}{\ell} \theta$$

Small Angles - PRS

Set your calculator to radians mode. Now take the sine of the angle 0.2 rad. By what percentage does this differ from 0.2?

- A. 0.0035
- B. 0.0066
- C. 0.66
- D. 99.3
- E. 3.5

Plane Pendulum

- we know how to solve this one already!

$$\Rightarrow \frac{d^2\theta}{dt^2} = -\frac{g}{\ell}\theta$$

$$\theta(t) = A \cos\left(\frac{2\pi t}{T}\right)$$

$$\frac{2\pi}{T} = \sqrt{\frac{g}{\ell}}$$

$$\Rightarrow T = 2\pi \sqrt{\frac{\ell}{g}}$$

We write here the solution in the case where we pull the pendulum bob out to some angle A (the amplitude) and let it go...

General S.H. Oscillator

- oscillations for any system governed by an equation of this form!

$$\Rightarrow \frac{d^2 x}{dt^2} = -\omega^2 x$$

$$x(t) = A \cos\left(\frac{2\pi t}{T}\right)$$

$$\frac{2\pi}{T} = \omega$$

$$\Rightarrow T = \frac{2\pi}{\omega}$$

Circular Motion – Oscillations

- simple harmonic oscillation in one dimension is just like considering only the “x” motion of circular motion!

$$x(t) = r \cos \omega t$$

$$y(t) = r \sin \omega t$$

Thank You!

It has been a privilege this past quarter to be your instructor, and I wish you all well for the rest of the year, in this course, and in all of your future endeavors.